

Doubled Terminated Reactance Lossless Two-ports

Most common situation, best sensitivity properties for matched termination conditions.

Power entering at port I equals the power leaving into load at port 2. If  $Z_1(j\omega) = R_G$  and  $Z_2(j\omega)=R_L$ , the maximum power (voltage, current) available from the source reaches the load, and any departure from the nominal value in an internal element can only lower it:

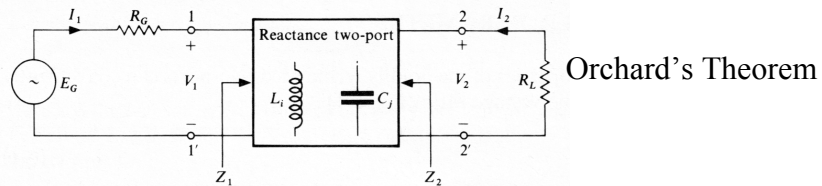

Figure 6-1 Doubly terminated reactance two-port.

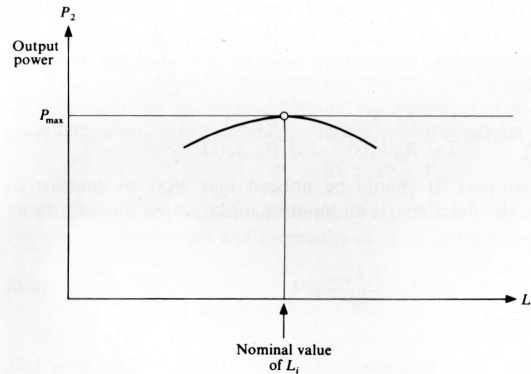
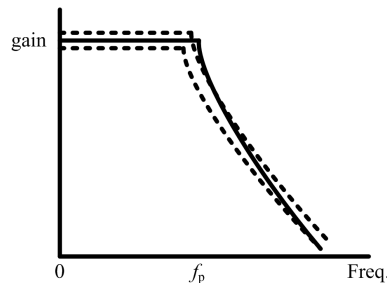

Figure 6-2 Output power  $P_2$  as a function of inductance  $L_i$ .

$f = 1 \text{ MHz}$

$$\frac{\delta|v_2|}{\delta L_i} = 0$$

The zero-sensitivity property holds strictly at the discrete frequencies where exact matching exists; for low loss, the sensitivity will be low. The sensitivity to variations in the terminating resistors is not very low, but nearly constant in the passbands of the two-port:



## 6-2 TRANSDUCER PARAMETERS

The transmission properties of the doubly terminated two-ports can conveniently be described using the voltage ratio (Fig. 6-1)

$$A_V = \frac{V_2(s)}{E_G} \quad (6-1)$$

since  $E_G$  is known. It is more expedient, however, to start out by considering the *power-transmission* properties of the two-port. Note that for singly or unterminated two-ports power-transfer relations were meaningless, since either the generator was a pure voltage or current source, with (theoretically) unlimited power-supplying capabilities or the load was an open or short circuit which required zero power for sustaining a nonzero output voltage or current, respectively. For doubly terminated two-ports, however, the generator can only supply a finite amount of power. This power, as is easy to prove, is at most

$$P_{\max} = \frac{E_G^2}{4R_G} \quad (6-2)$$

$P_{\max}$  is obtained only for a matched load, i.e., for  $Z_1 = R_G$  (Fig. 6-1).† At the same time, maintaining a voltage  $V_2$  across the resistor  $R_L$  requires a power input

$$P_2 = \frac{|V_2|^2}{R_L} \quad (6-3)$$

which is transformed into heat or radiant energy. Obviously, the relation

$$\frac{P_{\max}}{P_2} = \left| \frac{1}{2} \sqrt{\frac{R_L}{R_G}} \frac{E_G}{V_2} \right|^2 \geq 1 \quad (6-4)$$

must hold. The ratio  $P_{\max}/P_2$  therefore provides a well-defined measure of the power-transmission efficiency of the terminated two-port. For  $P_{\max}/P_2 = 1$ , all the power which the generator can supply is transmitted to the load; for  $P_{\max}/P_2 \rightarrow \infty$ , none of it is. It seems therefore logical to define and use, instead of  $A_V$ , the *transducer factor*

$$H(s) = \frac{1}{2} \sqrt{\frac{R_L}{R_G}} \frac{E_G}{V_2(s)} = \frac{1}{2} \sqrt{\frac{R_L}{R_G}} \frac{1}{A_V(s)} \quad (6-5)$$

to characterize the two-port. It should be noticed that  $H(s)$ , in contrast to previously defined transfer functions, is an input-quantity/output-quantity ratio. By (6-4), for a passive two-port

$$|H|^2 = \frac{P_{\max}}{P_2} \geq 1 \quad (6-6)$$

Transducer power gain:  $\frac{1}{|H|^2}$

Transducer voltage gain:  $\frac{1}{|H|}$

† Note that all voltages and currents in the discussions of this chapter refer to *effective* values. Thus, a voltage signal  $V_0 \cos(\omega t + \varphi)$  is denoted by its phasor  $V = (V_0/\sqrt{2})e^{j\varphi}$ .

Let the *transducer constant*  $\Gamma$  be defined as the natural logarithm of  $H$ :

$$\Gamma \triangleq \ln H = \alpha + j\beta \quad \alpha \triangleq \ln |H| \quad \beta \triangleq \angle H \quad (6-7)$$

Here  $\alpha$  is the *transducer loss* (in nepers), and  $\beta$  is the *phase lag* of the output voltage  $V_2$  behind  $E_G$ ;  $\beta$ , which is measured in radians, will simply be called the *phase* of the two-port.

It is usual to measure the loss in decibels. This unit is defined by

$$\alpha(\text{in dB}) = 20 \log |H| \quad (6-8)$$

Hence  $1 \text{ Np} = 20 \log e \text{ dB} \approx 8.686 \text{ dB}$  (6-9)

where Np is the abbreviation for nepers.

Other useful parameters of the doubly terminated two-port are the *reflection factors*. Referring to Fig. 6-1, we see that these are defined by the relations†

$$\rho_1 = \frac{R_G - Z_1}{R_G + Z_1} \quad (6-10)$$

and

$$\rho_2 = \frac{R_L - Z_2}{R_L + Z_2} \quad (6-11)$$

Here,  $Z_1$  is the impedance seen at the primary port (terminals 1-1'), with the secondary port terminated in  $R_L$

$$Z_1 = \frac{V_1}{I_1} \quad (6-12)$$

Similarly,  $Z_2$  is the driving-point impedance at the secondary port when the primary port is terminated by  $R_G$  (but with  $E_G$  set to zero and  $R_L$  removed). Note that with  $E_G$  at the primary port, as shown in Fig. 6-1,

$$\frac{V_2}{-I_2} = R_L \neq Z_2 \quad (6-13)$$

To give a physical meaning to the reflection coefficients, consider the power flow through the network. Although the generator is capable of supplying a maximum amount of power  $P_{\max}$ , in fact it supplies only

$$P_1 = \text{Re } V_1 I_1^* \leq P_{\max} \quad (6-14)$$

to the input of the two-port. Since the two-port is lossless,  $P_1$  travels through the two-port undiminished and eventually emerges as the power flow into the load:

$$P_2 = \frac{|V_2|^2}{R_L} = P_1 \quad (6-15)$$

Used in S parameters

† The alternative definitions  $\rho_1 = (Z_1 - R_G)/(Z_1 + R_G)$  and  $\rho_2 = (Z_2 - R_L)/(Z_2 + R_L)$  have some conceptual advantages and are also often used.

This realistic picture can be replaced by a hypothetical one as follows: the generator is assumed *always* to supply its maximum power  $P_{\max}$  to the primary port of the two-port. Because of the mismatch ( $R_G \neq Z_1$ ) a part  $P_r$  of  $P_{\max}$  is reflected from the two-port, and only the remainder

$$P_2 = P_{\max} - P_r \quad (6-16)$$

passes on to the load. The *reflected power*  $P_r$  leaves the two-port at port 1 and is eventually reabsorbed by the generator. The power flow is schematically illustrated in Fig. 6-3. It is readily recognized that in the steady state the two concepts described give the same results for the net power flow at any point in the network and hence the second interpretation (borrowed from the physics of transmission-line systems) is permissible.

By Eqs. (6-14) to (6-16),

$$P_r = P_{\max} - P_1 = \frac{E_G^2}{4R_G} - \operatorname{Re} I_1 I_1^* Z_1 \quad (6-17)$$

We denote

$$Z_1 = R_1 + jX_1 \quad (6-18)$$

Therefore for  $s = j\omega$

$$\begin{aligned} P_r &= \frac{E_G^2}{4R_G} \left( 1 - \frac{4R_G}{E_G^2} |I_1|^2 R_1 \right) = P_{\max} \left( 1 - \frac{4R_G R_1}{|R_G + Z_1|^2} \right) \\ &= P_{\max} \frac{(R_G + R_1)^2 + X_1^2 - 4R_G R_1}{|R_G + Z_1|^2} \end{aligned} \quad (6-19)$$

since  $I_1 = E_G / (R_G + Z_1)$ . After some simple calculation, we obtain

$$P_r = P_{\max} \left| \frac{R_G - Z_1}{R_G + Z_1} \right|^2 = P_{\max} |\rho_1|^2 \quad (6-20)$$

Hence,  $|\rho_1|^2$  is the ratio of the reflected power to the available generator power. Evidently,  $|\rho_1|^2 \leq 1$ .

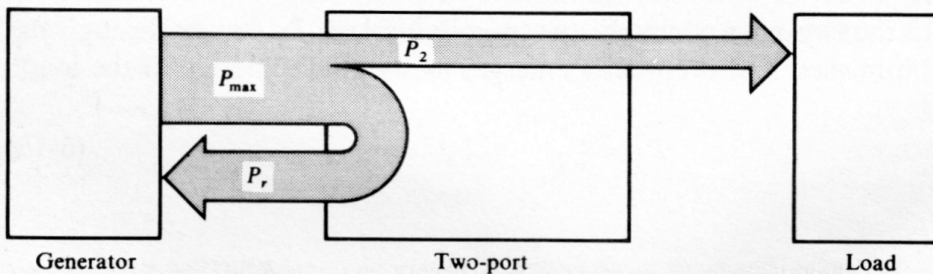

Figure 6-3 Power flow in a doubly terminated two-port.



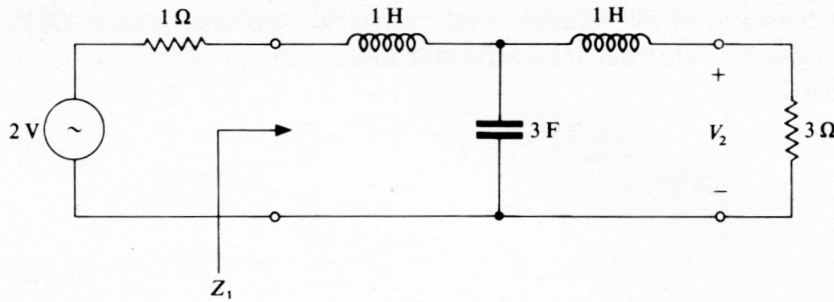

Figure 6-4 Two-port example.

**Example 6-1** Find  $P_{\max}$ ,  $P_r$ ,  $\rho_1$ ,  $P_2$ , and  $V_2$  for the circuit of Fig. 6-4 at  $\omega = 1$  rad/s. By elementary calculations

$$P_{\max} = \frac{2^2}{(4)(1)} = 1 \text{ W} \quad Z_1 = \frac{3s^3 + 9s^2 + 2s + 3}{3s^2 + 9s + 1}$$

and

$$\rho_1 = \frac{1 - Z_1}{1 + Z_1} = \frac{-3s^3 - 6s^2 + 7s - 2}{3s^3 + 12s^2 + 11s + 4}$$

Hence

$$|\rho_1|^2 = \frac{(6\omega^2 - 2)^2 + \omega^2(3\omega^2 + 7)^2}{(-12\omega^2 + 4)^2 + \omega^2(-3\omega^2 + 11)^2}$$

For  $\omega = 1$ ,  $|\rho_1|^2 = \frac{29}{32}$ . Hence

$$P_r = |\rho_1|^2 P_{\max} = \frac{29}{32} \text{ W} \quad P_2 = P_{\max} - P_r = \frac{3}{32} \text{ W}$$

On the other hand, by analyzing the network, we find

$$V_2 = \frac{6}{3s^3 + 12s^2 + 11s + 4}$$

and hence, for  $s = j1$ ,

$$|V_2|^2 = \frac{36}{(-12\omega^2 + 4)^2 + \omega^2(-3\omega^2 + 11)^2} = \frac{9}{32}$$

Therefore

$$P_2 = \frac{|V_2|^2}{R_2} = \frac{3}{32}$$

and

$$P_r = P_{\max} - P_2 = 1 - \frac{3}{32} = \frac{29}{32}$$

as obtained via  $|\rho_1|$ .

Next, we introduce the *characteristic function*  $K(s)$  of the terminated two-port by the definition

$$K(s) = \rho_1(s)H(s) \quad (6-21)$$

Then, for  $s = j\omega$ ,

$$|K|^2 = |\rho_1|^2 |H|^2 = \frac{P_r}{P_{\max}} \frac{P_{\max}}{P_2} = \frac{P_r}{P_2} \quad (6-22)$$

$$0 = |K|^2 < \infty$$

Thus,  $|K|^2$  gives the ratio of the reflected and transmitted powers. Hence  $|K|^2$  may take on any positive value between zero and infinity for  $s = j\omega$ .

The power relation

$$P_{\max} = P_r + P_2 \quad (6-23)$$

now gives

$$\frac{P_{\max}}{P_2} = \frac{P_r}{P_2} + 1 \quad (6-24)$$

or, by Eqs. (6-6) and (6-22), for  $s = j\omega$ ,

$$|H|^2 = |K|^2 + 1 \quad (6-25)$$

This equality (often called the *Feldtkeller equation*<sup>†</sup>) plays a central role in the design of doubly terminated two-ports.

By their definitions,  $H(s)$ ,  $\rho_1(s)$ , and  $K(s)$  are all rational functions of  $s$ , with real coefficients. Denoting their even and odd parts in  $s$  by the subscripts  $e$  and  $o$ , respectively, we have

$$H(s) = H_e(s) + H_o(s) \quad (6-26)$$

$$H(-s) = H_e(s) - H_o(s) \quad (6-27)$$

On the  $j\omega$  axis  $H_e(j\omega)$  is real and  $H_o(j\omega)$  is imaginary. Hence

$$|H(j\omega)|^2 = [H_e(j\omega)]^2 + \left[ \frac{H_o(j\omega)}{j} \right]^2 \quad (6-28)$$

$$|H(j\omega)|^2 = H_e^2(j\omega) - H_o^2(j\omega) = H(j\omega)H(-j\omega)$$

When we rewrite  $|K(j\omega)|^2$  this same way and replace  $j\omega$  by  $s$ , the Feldtkeller equation becomes

$$H(s)H(-s) = K(s)K(-s) + 1 \quad (6-29)$$

This form is much more convenient for numerical calculations than Eq. (6-25).

Note that the argument used in deriving Eq. (6-29) from Eq. (6-25) is valid only for  $s = j\omega$ . But Eq. (6-25) was only valid for  $s = j\omega$  to start with, since it was derived from steady-state power considerations. Hence, this restriction is harmless.

Next, some of the properties of  $H(s)$ ,  $\rho_1(s)$ ,  $\rho_2(s)$ , and  $K(s)$  will be discussed from a physical viewpoint. After writing  $H(s)$  in the form

$$H(s) = \frac{E(s)}{P(s)} \quad (6-30)$$

where  $E(s)$  and  $P(s)$  are polynomials, the properties of  $E(s)$  will be investigated. First of all, it is clear that the degree of  $E(s)$  must be equal to or greater than that

<sup>†</sup> From Eqs. (6-22) and (6-25),  $|H|^{-2} + |\rho_1|^2 = 1$ . Historically, it is this relation which is due to Feldtkeller.